

Frequency Response Analysis of Op Amp characteristics with the Circuit Sleuth frequency response analyzer.

John F. Iannuzzi

Introduction

The characteristics of the frequency response plots discussed in this application note will focus on the most common operational amplifier circuits and specifications. The first section will discuss how the gain bandwidth product of an op amp affects the inverting and non-inverting amplifier configurations. The second section will discuss the differential amplifier and common mode rejection.

Often, manufacturers data sheets do not include characteristic curves of amplifier performance over frequency. Two of the most important op amp parameters, namely gain-bandwidth product (GBP) and common mode rejection ratio (CMRR) may only be listed as a single value in a tabulation of specifications. It is important to realize that op amp characteristics *vary with frequency*. Usually there is a degradation of performance as frequency increases. The frequency response analysis curves measured in this application note will illustrate the role that frequency plays in these circuits.

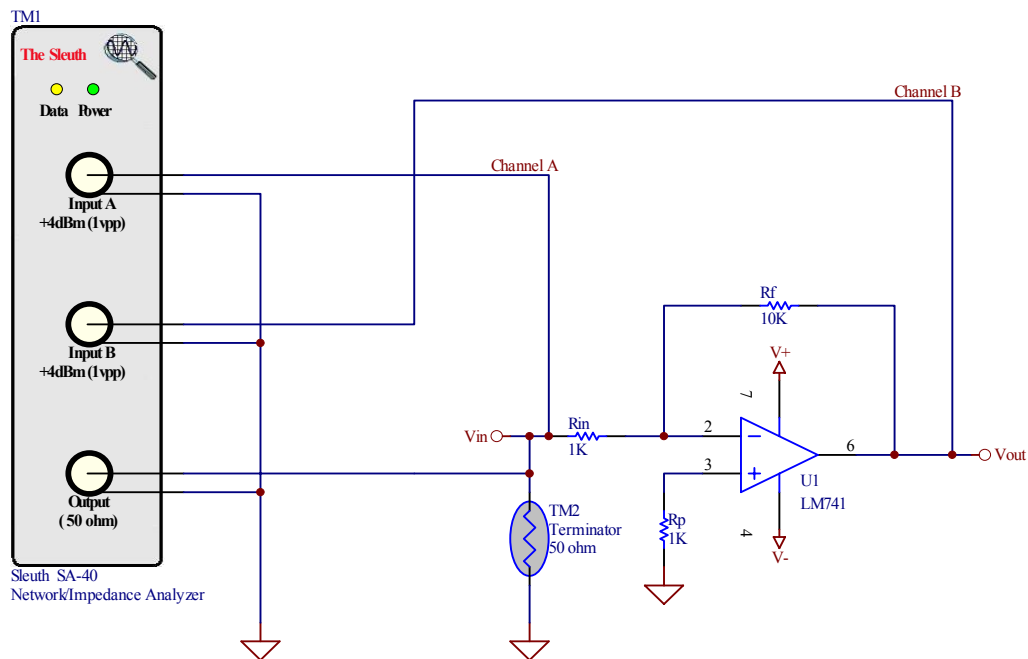

Why measure frequency response and why is it important?

The frequency response plot, or transfer function, with magnitude and phase gives us a *complete* picture of how an amplifier circuit performs over the specified frequency range. The following are some system parameters that are typically measured and why they are important.

System gain flatness and gain linearity. The plot of the magnitude indicates how a system amplifies signals in the pass band. It is important that *all* signals in the frequency band of interest (pass band) are amplified uniformly, i.e. that the gain is flat within the pass band.

System bandwidth. The frequency range over which the amplifier system is to operate with uniform gain. The bandwidth of the system is defined as the frequency point at which the gain falls to -3dB of the desired pass band gain. It is important to design a system that amplifies signals over a specified bandwidth and rejects out of bandwidth signals to limit system noise or to prevent unwanted, out of band signals from causing interference.

Stop band attenuation. The stop band is the bandwidth where all unwanted frequencies are attenuated by the system. It is important to know the stop band attenuation level to insure that all unwanted frequencies are sufficiently rejected or if additional attenuation is required.

Transition band. The transition band connects the pass band to the stop band and is the frequency range over which the pass band gain of the amplifier decreases past the -3dB point, and where the gain of the transition band is $+3\text{dB}$ above the stop band attenuation.

The transition band can be classified as single, double or multiple pole roll off. For example, a single pole roll off is classified as an attenuation rate of 20dB/decade and a double pole roll off is classified as an attenuation rate of 40dB/decade . Other filter structures, such as those implemented with Digital Signal Processing, may have very narrow transition regions that may not easily be classified with a standard attenuation rates. The width of the transition band is a characteristic of the amplifier or filter and indicates the circuits ability to quickly reject unwanted frequencies. In some communication systems, it is important to have a very narrow transition band and very high attenuation in the stop band because of close spacing between communication channels.

Phase. The phase of the output signal relative to the input signal over the frequency range is important in linear amplifiers, especially in audio systems, where two *identical* amplifiers are used simultaneously. Any significant relative phase shift or phase mismatch between the left and right audio channels will cause phase distortion in the audio program material, resulting in an unpleasant listening experience. Amplifiers in instrumentation systems require phase matching because many amplifiers are used simultaneously.

Together, phase and magnitude plots are used to characterize system stability in feedback control systems. For example, in a robotic application, it may be necessary to position the robot arm precisely in order to weld two items together in a manufacturing plant. The arm is on a production line so it must position itself and perform the welding operation rapidly or throughput will suffer. The designer of the robot arm must use frequency response analysis to design the system for optimum speed and position accuracy. An important parameter that characterizes control system stability is *phase margin*. The phase margin is measured relative to the 0dB crossing of the magnitude response. This is a good example of how the magnitude and phase plots are used together.

Only a frequency response analyzer can give a complete image of a systems magnitude/phase performance and completely characterize control system stability.

Let's get started with the LM741 op amp.

Why the LM741?

The LM741 is a time proven, reliable and robust amplifier. There are hundreds of application circuits and experiments for the 741. It is chosen for introductory electronics courses in colleges and technical schools to demonstrate op amp theory and principals. It is readily available, cost effective and great for general-purpose applications. As the workhorse of the industry, the LM741 is manufactured by a number of companies including National Semiconductor, Texas instruments, Fairchild, etc.

Gain-bandwidth product (GBP) and the inverting amplifier.

One of the most important op-amp specifications is the gain-bandwidth product. It is, in many cases, the first specification that a designer will focus on when selecting parts for an application.

What is the Gain Bandwidth Product?

The gain-bandwidth product is a measure of the *maximum* frequency or bandwidth that the amplifier will support or amplify. The GBP can be determined from a chart provided in the op amp data sheet. In some cases the GBP of the amplifier will be listed in the table of parameters in the data sheet. Gain-Bandwidth product is specified as the *maximum* frequency that the amplifier will pass with the gain of the amplifier set to 1, or unity. A gain of 1 is also 0dB on the logarithmic scale. The unit of the specification is in frequency, usually megahertz (Mhz). For the LM741, typically:

$$\text{Gain} \cdot \text{Bandwidth} = 1\text{Mhz}$$

Note what happens to the bandwidth when the gain is increased or decreased.

It is useful to have a gain-bandwidth plot of the of the op amp for reference. The plot can be found in the data sheet or one can be created using the GBP specification.

Graph the GBP on a log-log scale with frequency plotted on the horizontal axis and gain plotted on the vertical axis. The gain can be represented in linear terms or in dB. This way, the chart can be drawn very quickly noticing that the GBP line is a simple pole, or a line with a negative slope of 20dB/Decade:

$$\frac{1}{s} @ 1\text{Mhz} = 0\text{dB}$$

The first amplifier configuration that will be looked at is an inverting amplifier with a gain of -10, or 20 dB, on the logarithmic scale.

The gain, A_v , of an inverting amplifier is:

$$A_v(\text{inv}) = -\frac{V_{out}}{V_{in}} = -\frac{R_f}{R_{in}} = -\frac{10K}{1K} = -10$$

The schematic is shown in figure 1.

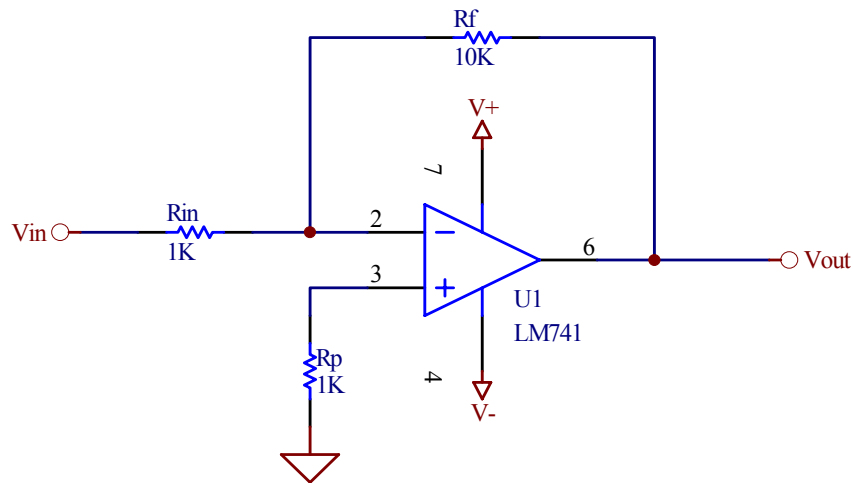

Figure 1. LM741 in the inverting amplifier configuration.

The resistor on the non-inverting input is equal to the parallel resistance of the gain resistors. This is done to cancel or minimize any input offset voltage generated by the input bias currents flowing out of the inverting and non-inverting inputs. If this is not done, the voltage offset will be amplified by the gain and may cause a significant DC offset error at the output of the amplifier.

The frequency response, or *transfer function*, of the amplifier can be measured with the Circuit Sleuth frequency response analyzer. The test setup is shown in figure 2.

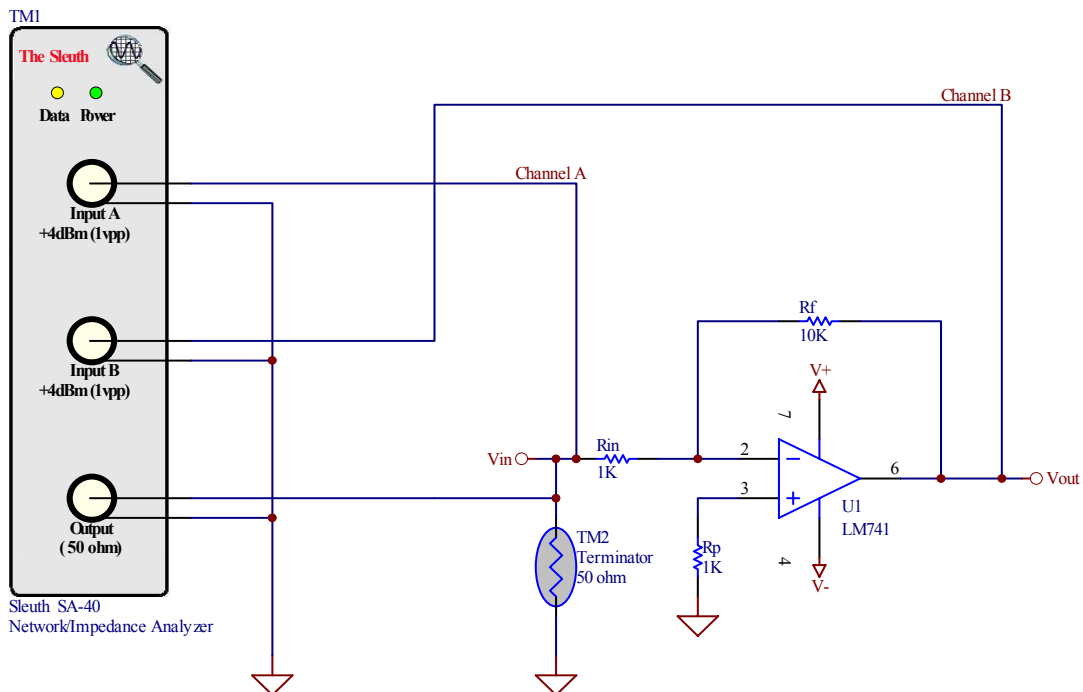

Figure 2. Circuit Sleuth connection to the amplifier circuit for measuring frequency response (transfer function).

For this measurement, the Circuit Sleuth is set up to perform a frequency sweep over the range of 20Hz – 2Mhz. The amplitude of the sine wave source is -16dBm or 100mVpp. The virtual front panel is set up to show phase (Blue) and magnitude (Red) of the transfer function. The format of the measurement is the ratio of B (output) to A (input), and the scaling on the vertical axis is in dB for the magnitude and degrees for phase.

The frequency response of the amplifier circuit is shown in figure 3.

The magnitude scale is set for a minimum of -20db and a maximum of +80db. Note that the point at which the magnitude plot crosses 0db is approximately 0.6Mhz. This is the GBP for this particular amplifier and is within the range of 0.437Mhz-1.5Mhz as tabulated in the LM741 data sheet.

The phase plot range is from +180 degrees to -180 degrees (360 degrees total). For an inverting amplifier the phase of the output signal relative to the input signal within the pass band is shifted by 180 degrees. Note that in the plot, the phase indicated is +180 degrees. A signal shifted by +180 degrees is indistinguishable from a signal shifted by -180 degrees.

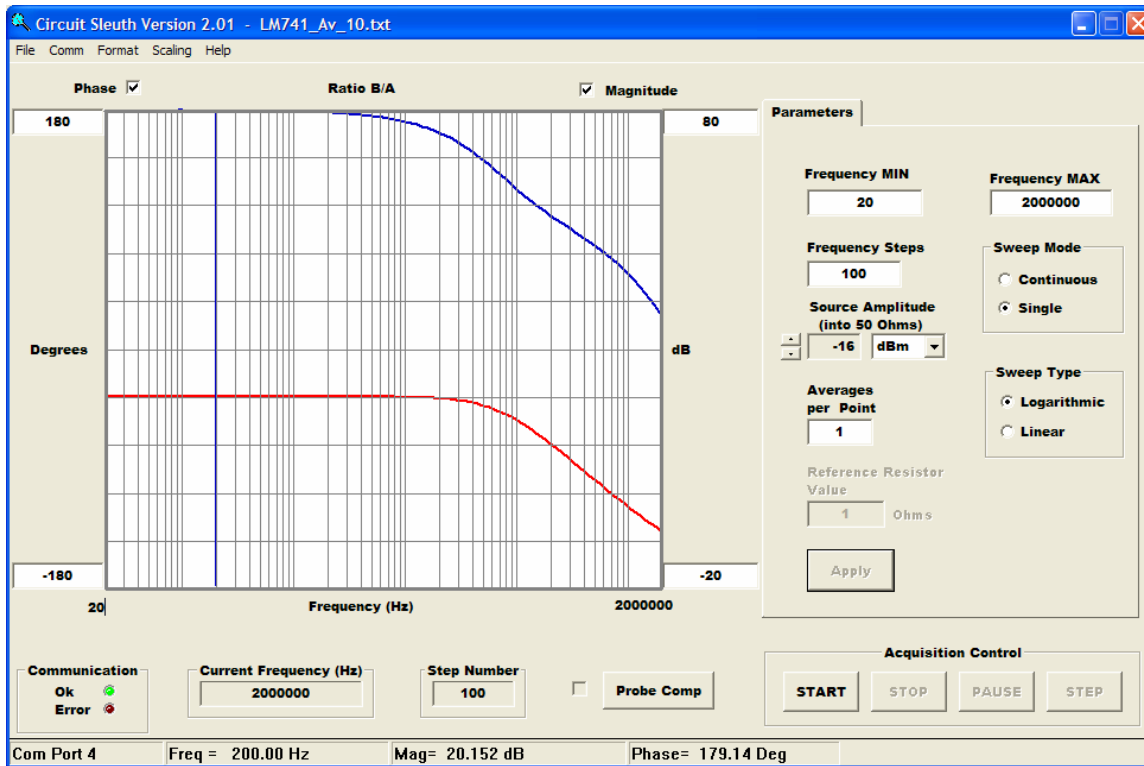

Figure 3. Circuit Sleuth output of the transfer function of LM741 configured as an inverting amplifier with a gain of -10 .

Figure 4 illustrates the same amplifier with the gain of the circuit configured to -100 or 40 db on the logarithmic scale. Note that the 0 dB frequency is close to the GBP of the amplifier configured with the gain of -10 but the pass band has narrowed and the slope of the transmission band remains the same. The slope of the transmission band should resemble the GBP plot that was derived from the data sheet. The GBP plot illustrates the range of gain and frequency that the amplifier can successfully support.

*It is a common mistake during the design phase, to overlook the fact that the gain-bandwidth product is frequency dependent especially when some data sheets express the GBP as a single value not illustrated in a chart. **It is important to refer to a gain-bandwidth plot during the design phase to insure that the design meets specification.***

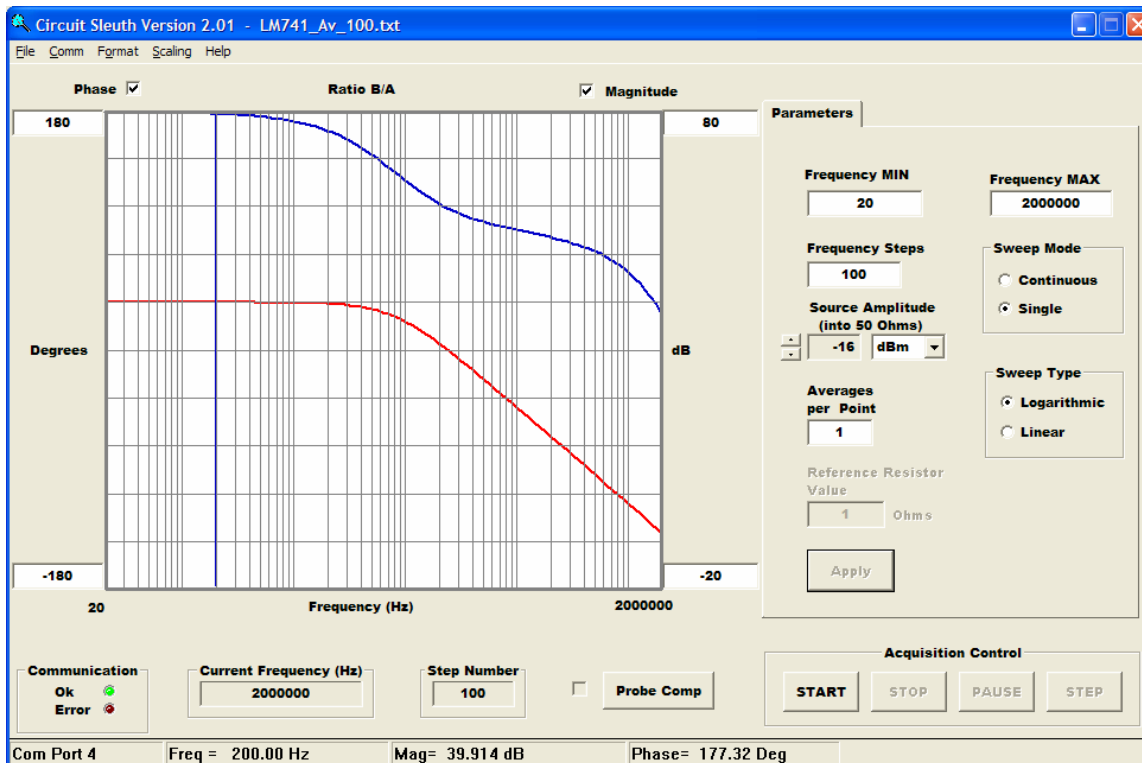

Figure 4. Circuit Sleuth output of the transfer function of LM741 configured as an inverting amplifier with a gain of -100 .

The non-inverting amplifier.

The op amp non-inverting amplifier does not shift the output signal by 180 degrees referred to the input signal. This is useful when it is important to keep the output signal in phase with the input signal. When the inverting amplifier configuration is used it is necessary to use an additional inverting amplifier to regain the phase integrity of the signals.

The gain, A_v , of the non-inverting amplifier is:

$$A_v(\text{non}) = \frac{V_{out}}{V_{in}} = 1 + \frac{R_f}{R_{in}} = 1 + \frac{10K}{1K} = 11$$

The schematic is shown in figure 5.

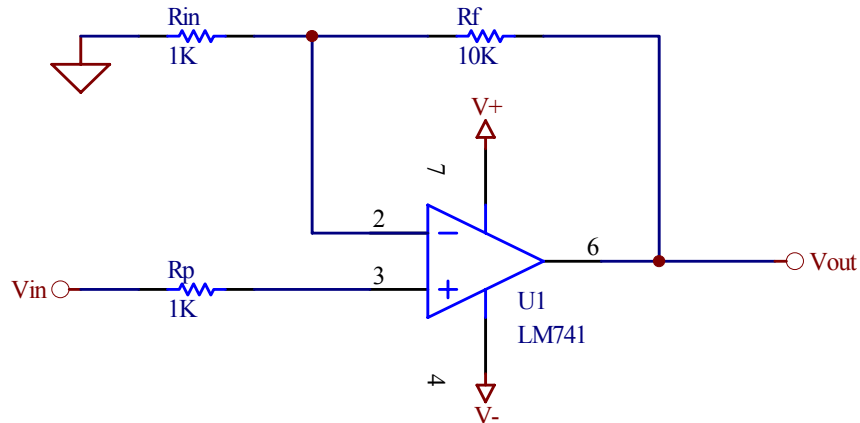

Figure 5. LM741 in the non-inverting amplifier configuration.

The test setup for measuring the frequency response of the non-inverting amplifier is shown in figure 6. It is similar to that of the inverting amplifier.

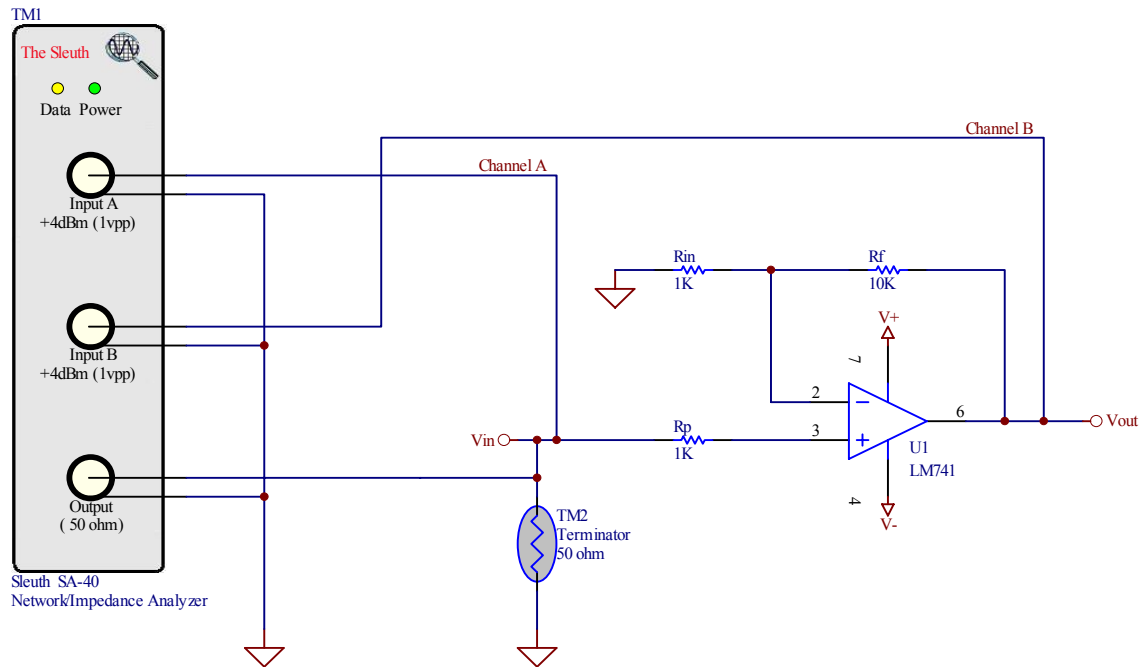

Figure 6. Circuit Sleuth connection to the non-inverting amplifier circuit for measuring frequency response (transfer function).

The frequency response of the amplifier circuit is shown in figure 7.

The magnitude scale is set for a minimum of -10dB and a maximum of $+90\text{dB}$. The point at which the magnitude plot crosses 0dB is approximately the 0.6MHz GBP for this amplifier. This verifies the GBP for the non-inverting configuration as well. The gain for the non-inverting configuration is slightly higher than that of the inverting configuration. This is illustrated in the magnitude plot.

Note that the phase is zero degrees in the pass band. This verifies that the non-inverting amplifier does not phase shift the signal by 180 degrees.

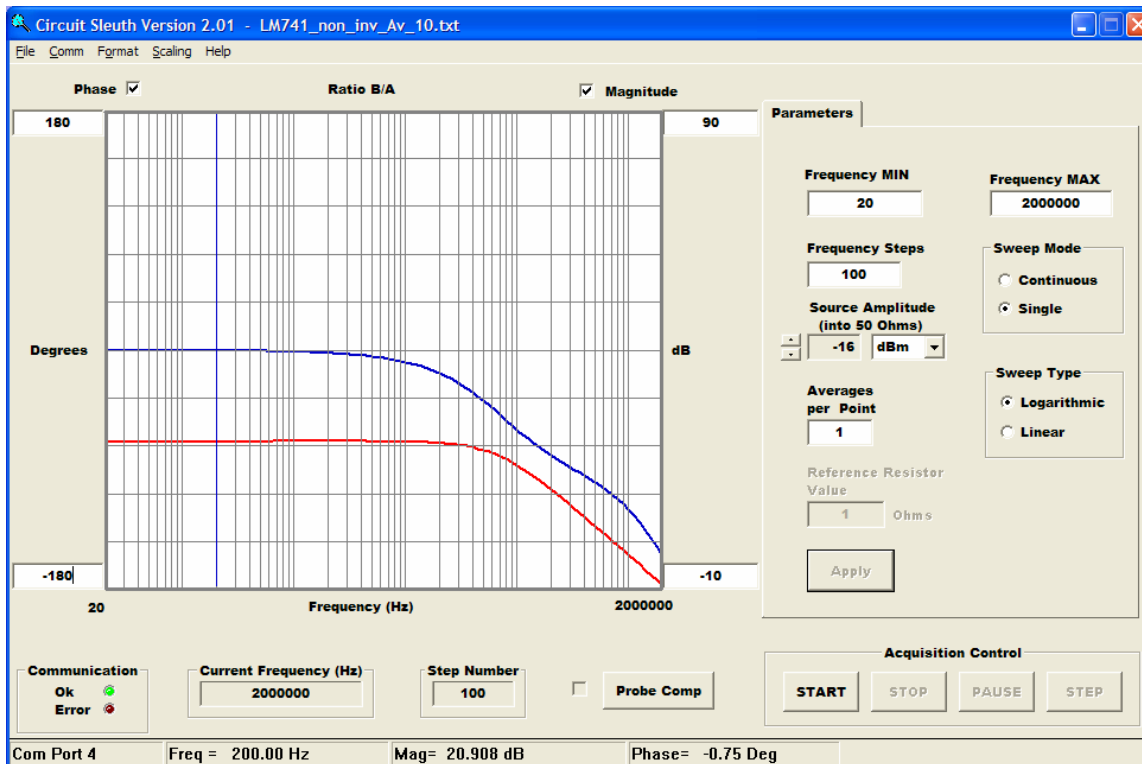

Figure 7. Circuit Sleuth output of the transfer function of LM741 configured as a non-inverting amplifier with a gain of 11.

The Differential amplifier and Common Mode Rejection

An op amp configured as a differential amplifier will amplify only the *difference* in the signals presented to the inverting (-) and non-inverting (+) inputs. The schematic of the differential amplifier is shown in figure 8. The output voltage of the circuit is expressed as:

$$V_{out} = V_2 \cdot \left(\frac{R_p}{R_p + R_2} \right) \cdot \left[1 + \frac{R_f}{R_1} \right] - V_1 \cdot \frac{R_f}{R_1}$$

If, $R_1 = R_2$ and $R_p = R_f$:

$$V_{out} = (V_2 - V_1) \cdot \frac{R_f}{R_1}$$

This implies that the differential amplifier should reject a common signal, or a signal with exactly the same characteristics, applied simultaneously to the inverting and non-inverting inputs of the op amp. The frequency response plot will be similar to the amplifier configurations previously discussed.

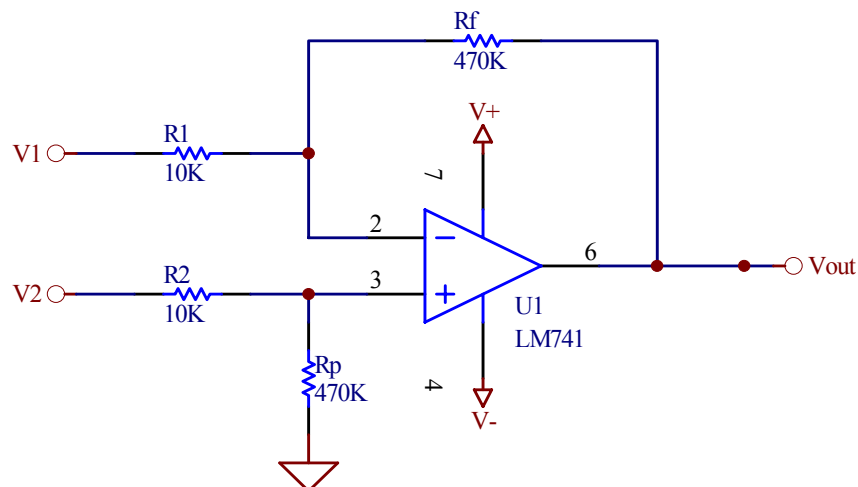

Figure 8. LM741 configured as a differential amplifier.

Common Mode Rejection Ratio (CMRR) is a measure of the amplifiers ability to reject similar signals applied simultaneously to the inverting and non-inverting

inputs. CMRR is a frequency dependant parameter. The op amps ability to reject common mode signals degrades as frequency increases.

Why is common mode rejection important?

As mentioned, one of the advantages of an op amp is its ability to amplify voltage differences and reject similar voltages. Many practical applications have a differential amplifier configured at the end of a long twisted pair of wires. This may be done in a factory where pressure or temperature is to be measured remotely. If the twisted pair is located, for example, in a factory or a place where there is a lot of electrical noise, the noise signal will appear on both the V1 and V2 inputs. The op amp will cancel the unwanted noise because of its high common mode rejection and amplify the differential signal cleanly.

Common Mode Rejection Ratio is usually stated in dB and defined as:

$$CMRR = \left| \frac{A_{DM}}{A_{CM}} \right|$$

Where A_{DM} is the differential mode gain of the amplifier and A_{CM} is the common mode gain of the circuit.

The differential mode gain (A_{DM}) of the circuit of figure 8 is:

$$A_{DM} = \frac{V_{out}}{(V2 - V1)} = \frac{Rf}{R1}$$

Ideally, the common mode gain would be 0. The common mode gain (A_{CM}) of the amplifier circuit is measured by injecting a signal into the inverting and non-inverting inputs of the circuit simultaneously then measuring the ratio of the output signal to the input signal (transfer function). If possible, match Rf - Rp and $R1$ - $R2$. Using 1% resistors is a good start.

Note. CMRR measurements are sensitive to the matching of component values. Precision resistors are used by the manufacturer of the op amp to increase the accuracy of the CMRR measurement.

The frequency response test setup for measuring the common mode gain of the differential amplifier is shown in figure 9.

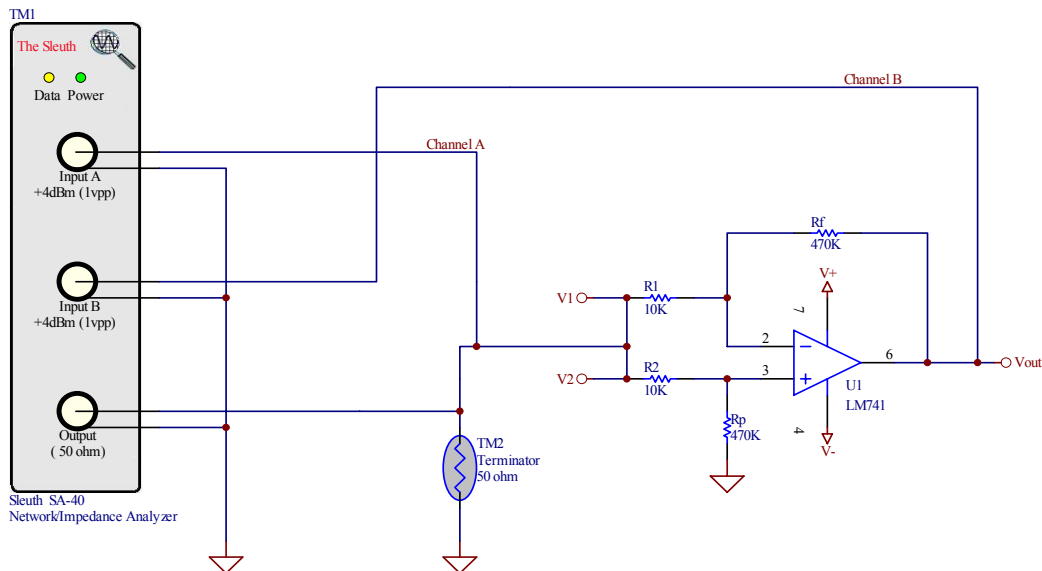

Figure 9. Circuit Sleuth connection to the differential amplifier setup for measuring the Common Mode Gain (A_{CM}) of the LM741.

The Common Mode Rejection Ratio can be calculated from the differential mode gain and the measured common mode gain.

$$A_{DM} = 47$$

$$A_{DM} \text{ dB} = 20\log(47) = 33.4 \text{ dB}$$

From the common mode gain frequency response plot in figure 10, the common mode gain (already in dB units), at 195 Hz is:

$$A_{CM} \text{ dB} = -43.9 \text{ dB}$$

$$\text{CMRR dB} = 33.4 \text{ dB} - (-43.9 \text{ dB}) = \mathbf{77.3 \text{ dB}}$$

The measurement is in agreement with the LM741 data sheet where the CMRR is specified between 70-90 dB.

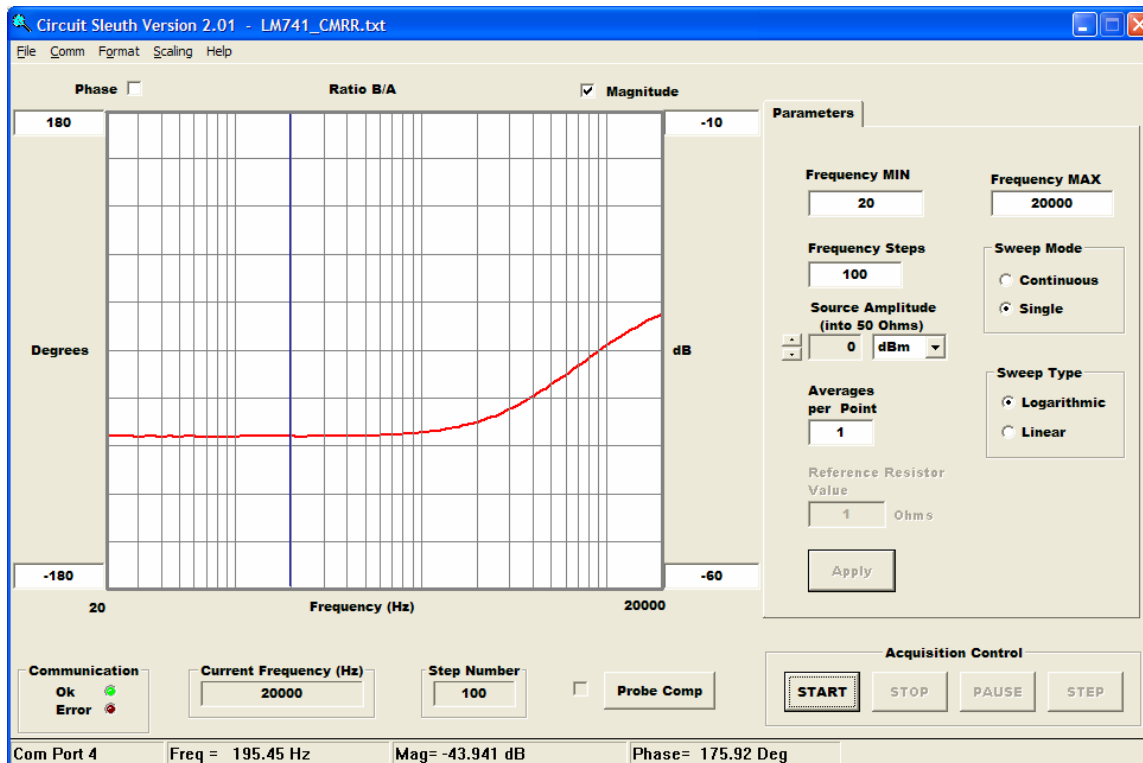

Figure 10. Circuit Sleuth output of the Frequency response of the Common Mode Gain (A_{CM}) of the LM741.

Summary

This application note discussed some of the most common op amp circuits and how frequency affects the performance of the circuit and op amp parameters.

For the inverting and non-inverting amplifiers, the gain-bandwidth product curve was estimated from the parameter specified in the data sheet and verified by performing a frequency response analysis on each of the circuit configurations.

The frequency response analysis of each circuit configuration illustrated that there is a trade off between gain and bandwidth. This trade off must be recognized when designing with op amps.

For the differential amplifier, the common mode rejection ratio was estimated by calculating the differential mode gain (A_{DM}) with the given component values and measuring the common mode gain (A_{CM}) with the frequency response analyzer. ***The frequency response analysis illustrated that CMRR starts***

to degrade at a much lower frequency than the gain-bandwidth product. It was stated that component matching is important in maximizing CMRR. The degradation of CMRR with frequency must be recognized when designing with op amps.

References:

1. Data sheet, LM741 **Operational Amplifier**, National Semiconductor, <http://www.national.com/>.
2. Chapter 1, Walter Jung, Editor, **Op Amp Applications**, Analog Devices, 2002, <http://www.analog.com>, ISBN:0-916550-26-5.
3. Chapter 5, Mohammed S. Ghausi, **Electronic Devices and Circuits: Discrete and Integrated**, CBS College Publishing, 1985, ISBN:0-03-062481-9.